





# PERI-LOC<sup>◇</sup> VLP Variable-Angle Locked Plating System

## Surgical Technique

### Table of Contents

<b>Product Overview</b> .....	2
Introduction.....	2
Indications and Contraindications .....	3
Case Examples .....	4
Design Features and Benefits .....	7
<b>PERI-LOC VLP System Overview</b> .....	8
<b>Surgical Technique</b> .....	12
Fracture Reduction .....	12
3.5mm Lateral Distal Fibula Locking Plate .....	14
3.5mm Posterolateral Distal Fibula Locking Plate .....	15
3.5mm Lateral Proximal Tibia Locking Plate.....	16
3.5mm Posteromedial Proximal Tibia Locking Plate .....	17
3.5mm Medial Distal Tibia Locking Plate .....	18
3.5mm Anterior Distal Tibia Locking Plate .....	19
3.5mm Posterior Distal Tibia Locking Plate .....	20
<b>Screw Insertion</b> .....	21
3.5mm Cortex Screw .....	21
3.5mm Locking Screw & 5.0mm Osteopenia Screw .....	22
2.7mm Cortex Screw .....	23
Closure .....	24
<b>Catalog Information</b> .....	25

#### Nota Bene

The technique description herein is made available to the healthcare professional to illustrate the author's suggested treatment for the uncomplicated procedure. In the final analysis, the preferred treatment is that which addresses the needs of the specific patient.

# Product Overview

## Introduction

The clinical challenges presented by the partial articular fracture (AO/OTA Fracture Classification Type B) require specific implants to achieve optimal intraoperative results. Factors such as intra-articular fracture extension, fracture pattern instability, and inadequate soft tissue coverage demand that implant systems be both versatile and comprehensive in their approach to fracture fixation.



Traditional locked plating systems maximize fracture stability through pre-determined screw trajectories and precise plate position on bone. This enhanced stability can, however, come at the price of reduced intraoperative versatility with respect to plate and screw placement.

Polyaxial locked plating systems, on the other hand, approach the same goal, but with a much greater degree of freedom relative to final implant position. Current designs use screw hole inserts, pre-loaded bushings, or threaded caps to establish fixed angle stability. While these devices do create an angularly stable construct, they also require additional implants and may add to the overall surgical procedure.



The PERI-LOC<sup>®</sup> VLP Variable-Angle Locked Plating System combines the benefits of both fixed angle and polyaxial locked plating concepts into one simple, intuitive system of instruments and implants. A full complement of plates and screws addresses not only fractures of the proximal and distal tibia, but the distal fibula as well. Locking screws can be angled through the plate holes up to 15° in any direction and require no additional implants or procedural steps to ensure definitive locking. Low profile fixation in areas where implant prominence is a chief concern is accomplished by minimizing plate thickness near the joint without compromising implant strength.

With its intuitive instrumentation and a versatile and comprehensive range of implants, the PERI-LOC VLP Variable-Angle Locked Plating System is a superior solution to complex fracture problems.

## Indications

The PERI-LOC<sup>®</sup> VLP Variable-Angle Locked Plating System is indicated for the treatment of partial articular fractures of the distal and proximal tibia (AO/OTA Fracture Classification Type B\*), and for fracture fixation of the fibula.

The PERI-LOC VLP 3.5mm One-Third Tubular Locking Plates are indicated for the treatment of fractures, non-unions and osteotomies of the medial malleolus, fibula, distal ulna, olecranon, calcaneus and metatarsals.

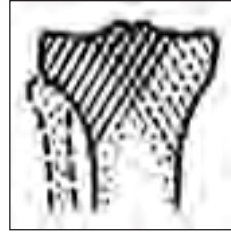

Partial articular (41-B)\*

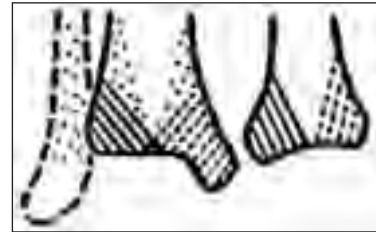

Partial articular (43-B)\*

## Contraindications

The PERI-LOC VLP Variable-Angle Locked Plating System is contraindicated for the treatment of AO/OTA Fracture Classification Types A & C and fractures with extreme metaphyseal comminution or dissociation of the articular segment from the shaft.

**Note** PERI-LOC VLP Variable-Angle Locked Plating System implants are indicated for single use only.

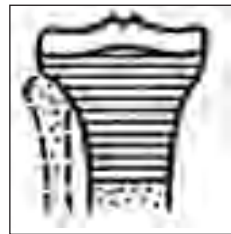

Extra-articular (41-A)\*

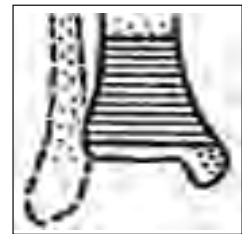

Extra-articular (43-A)\*

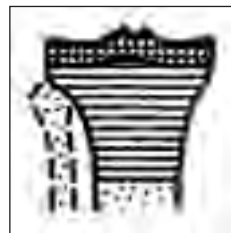

Complete articular (41-C)\*

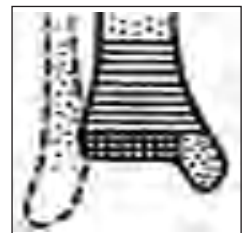

Complete articular (43-C)\*

\*OTA Fracture Classification courtesy of the Orthopaedic Trauma Association. For more information, go to [www.ota.org](http://www.ota.org)

## PERI-LOC<sup>®</sup> VLP Case Examples

### 3.5mm Posteromedial Proximal Tibia Locking Plate



### 3.5mm Lateral Proximal Tibia Locking Plate

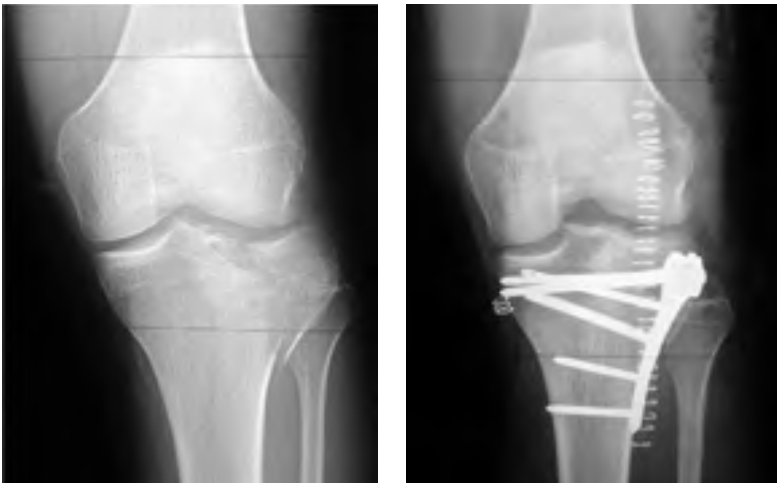

### 3.5mm Anterior Distal Tibia Locking Plate

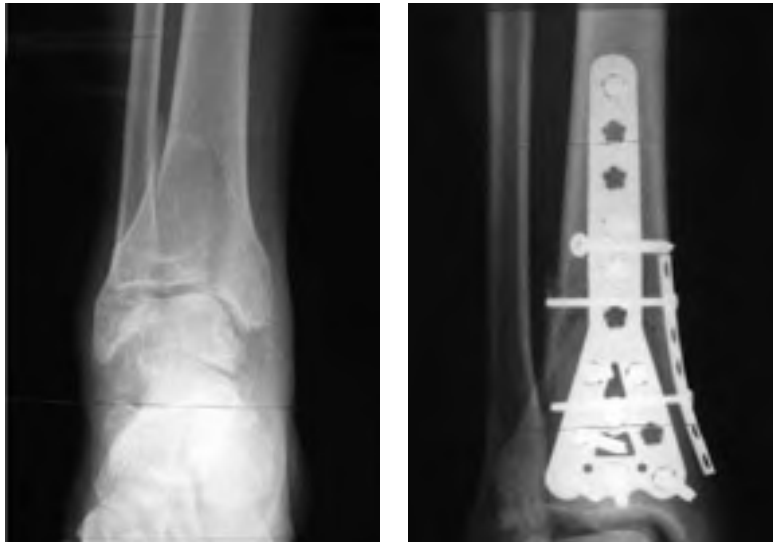

### 3.5mm Lateral Distal Fibula Locking Plates



3.5mm Posterior Distal Tibia and 3.5mm Posterolateral Distal Fibula Locking Plates



## Design Features and Benefits

### Polyaxial Locking Plate

Each PERI-LOC<sup>®</sup> VLP screw hole contains five separate tabs that engage with the threads of the locking screw head to form a fixed angle construct. Locking screws can be angled and locked up to 15° in any direction allowing for the creation of customized, multi-directional locked plating constructs. Each screw hole accepts 3.5mm Cortex, 3.5mm Locking and/or 5.0mm Osteopenia Screws.



### Low Profile Implants

The profile of the PERI-LOC VLP locking plate is designed to ensure low profile fracture fixation in areas of minimal soft tissue coverage such as periarticular zones. All screws in the PERI-LOC VLP Locked Plating System have a low head profile to further reduce the potential for soft tissue irritation in these sensitive areas.



### Optimal Plate Contour

The optimized contour of the PERI-LOC VLP locking plate facilitates both fracture reduction and stabilization as it is compressed to bone. This "compression contouring" feature is essential to the implant's ability to resist torque and bending during fracture healing. Once securely fixed in place, the plate produces a constant buttress effect to the fracture site to prevent loss of reduction and to enhance overall fracture fixation.



# PERI-LOC<sup>◇</sup> VLP System Overview

## PERI-LOC VLP Plates

### 3.5mm Lateral Distal Fibula Locking Plate

- Distal screw cluster and low plate profile provide stable periarticular fixation
- 2.0mm – 1.7mm proximal to distal plate thickness transition
- Left and right specific



### 3.5mm Posterolateral Distal Fibula Locking Plate

- Scalloped for syndesmotic screw placement outside the plate without compromising plate position
- 1.5mm – 0.9mm proximal to distal plate thickness transition
- Left and right specific
- 8° distal helical twist accommodates the posterolateral anatomy of the distal fibula
- Rounded distal edges to minimize peroneal nerve irritation



### 3.5mm One-Third Locking Tubular Plate

- Low-profile buttress plate for fractures of the distal fibula
- Consistent 1.5mm plate thickness



### **3.5mm Posterior Distal Tibia Locking Plate**

- Scalloped to allow lag screw placement without compromising plate position
- Contour facilitates a posterior approach to distal tibia fractures in the coronal plane
- Consistent 1.5mm plate thickness
- Left and right specific



### **3.5mm Anterior Distal Tibia Locking Plate**

- Scalloped to allow lag screw placement without compromising plate position
- Contour facilitates an anterior approach to distal tibia fractures in the coronal plane
- Consistent 1.5mm plate thickness
- Left and right specific



### **3.5mm Medial Distal Tibia Locking Plate**

- Smooth distal tip minimizes soft tissue irritation over the medial malleolus
- 2.0mm – 1.5mm proximal to distal plate thickness transition
- Contour facilitates a medial approach to distal tibia fractures in the sagittal plane
- Left and right specific



### **3.5mm Posteromedial Proximal Tibia Locking Plate**

- Contoured to provide a stable buttress platform for fractures of the medial tibial plateau
- Consistent plate thickness:
  - 1.5mm = 4 hole
  - 2.0mm = 7 hole
- Left and right specific



### **3.5mm Lateral Proximal Tibia Locking Plate**

- Scalloped to allow lag screw placement without compromising plate position
- 1.5mm – 2.0mm proximal to distal plate thickness transition
- Left and right specific
- 3° AP radius of curvature optimizes plate coverage down the tibial shaft and proximal screw position



## PERI-LOC<sup>◇</sup> VLP Screws

- Standard 2.5mm hex head recess for all screws
- Low profile heads to reduce soft tissue irritation
- Screw angulation in each plate hole:
  - 3.5mm Cortex: 20°
  - 3.5mm Locking: 15°
  - 5.0mm Osteopenia: 15°
- Self-Tapping 2.7mm Cortex, 3.5mm Cortex and 3.5mm Locking Screws
- 5.0mm Osteopenia Screw (fully and partially threaded) provides superior purchase and compression in poor quality bone stock
- Standardized drill bits:
  - 2.7mm Drill Bit: 3.5mm and 5.0mm screws
  - 2.0mm Drill Bit: 2.7mm screws



**3.5mm Cortex Screw**



**3.5mm Locking Screw**



**5.0mm Osteopenia Screw  
Fully Threaded**



**5.0mm Osteopenia Screw  
Partially Threaded**



**2.7mm Cortex Screw**

# Surgical Technique

## Fracture Reduction

Articular fracture components must be anatomically reduced prior to plate application and screw insertion. Reduction aids should be placed so as not to interfere with final plate placement. Reduce and provisionally secure fracture fragments using:

- K-Wires\*

1.25mm x 150mm (7116-1012)

1.6mm x 150mm (7116-1016)

2.0mm x 150mm (7116-1020)

**Note** If K-Wires are to be inserted through the holes on a PERI-LOC® VLP locking plate for the purpose of provisional fixation, it is recommended that 1.6mm K-Wires be used.

- Provisional Fixation Pins\*

2.7mm x 14mm (7117-1228)

2.7mm x 25mm (7117-1229)

2.7mm x 40mm (7117-1230)

**Note** Provisional Fixation Pins may be inserted on power, but should always be seated manually in order to avoid stripping of the threads and loss of purchase.

- Ball Spike Pusher (7117-1210)\*\*

- Reduction Forceps\*\*

Ball Spike Reduction Clamp, Medium (7117-1212)

Ball Spike Reduction Clamp, Large (7117-1213)

Ratchet Reduction Forceps (7117-0044,  
7117-3370, 7117-3377, 7117-3378)

Fibula Clamp (7117-1211)



\*Located in the PERI-LOC VLP Instrument Tray

\*\*Located in the PERI-LOC Periarticular Forceps Tray

- Ball Spike Reduction Clamp:  
Assemble either the 15mm or 25mm Spiked Washer (7117-1220, 7117-1221)\* to the ball spike clamp by pushing the tip of the clamp into the washer until it snaps on.

Care should be taken when handling the clamps and spiked washers to avoid the sharpened tips.

If the ball spike clamp is to be used with a plate, insert one of the tips into the desired plate hole and engage the other tip with the bone on the opposite cortex. If using a spiked washer on the far-side clamp tip, ensure that the spikes are against bone.

\*Located in the PERI-LOC® Periarticular Forceps Tray

## 3.5mm Lateral Distal Fibula

### Patient Positioning

Place the patient in the supine position on a radiolucent table. Confirm unimpeded AP and lateral visualization of the distal fibula under fluoroscopy.

### Plate Selection

Following fracture reduction, select the 3.5mm Lateral Distal Fibula Locking Plate that best accommodates patient anatomy and fracture pattern.

**Note** The PERI-LOC<sup>®</sup> VLP 3.5mm Lateral Distal Fibula Locking Plate Preoperative Template (7118-1180) is available to assist with pre-operative radiographic planning.

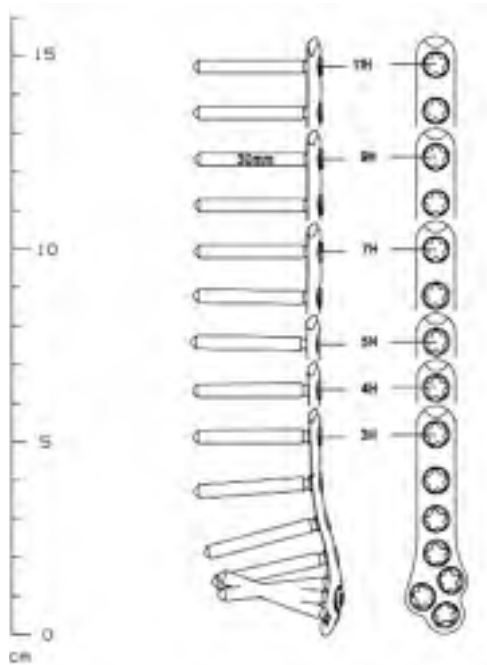

PERI-LOC VLP 3.5mm Lateral Distal Fibula Locking Plate  
Preoperative Template  
Cat. No. 7118-1180

### Plate Positioning

The plate lies along the lateral aspect of the distal fibula with the distal screw cluster covering the lateral malleolus. Provisionally fix the plate to bone using Reduction Forceps and/or Provisional Fixation Pins and proceed with screw insertion as desired.



## 3.5mm Posterolateral Distal Fibula

### Patient Positioning

Place the patient in the supine position on a radiolucent table. Confirm unimpeded AP and lateral visualization of the distal fibula under fluoroscopy.

### Plate Selection

Following fracture reduction, select the 3.5mm Posterolateral Distal Fibula Locking Plate that best accommodates patient anatomy and fracture pattern.

**Note** The PERI-LOC<sup>®</sup> VLP 3.5mm Posterolateral Distal Fibula Locking Plate Preoperative Template (7118-1199) is available to assist with pre-operative radiographic planning.

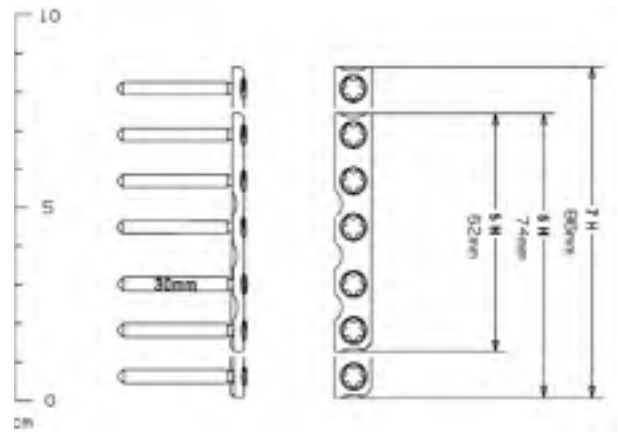

PERI-LOC VLP 3.5mm Posterolateral Distal Fibula Locking Plate Preoperative Template  
Cat. No. 7118-1199

### Plate Positioning

The plate lies along the posterolateral aspect of the distal fibula. Provisionally fix the plate to bone using Reduction Forceps and/or Provisional Fixation Pins and proceed with screw insertion as desired.



## 3.5mm Lateral Proximal Tibia

### Patient Positioning

Place the patient in the supine position on a radiolucent table. Confirm unimpeded AP and lateral visualization of the proximal tibia under fluoroscopy.

### Plate Selection

Following fracture reduction, select the 3.5mm Lateral Proximal Tibia Locking Plate that best accommodates patient anatomy and fracture pattern.

**Note** The PERI-LOC<sup>®</sup> VLP 3.5mm Lateral Proximal Tibia Locking Plate Preoperative Template (7118-1182) is available to assist with pre-operative radiographic planning.

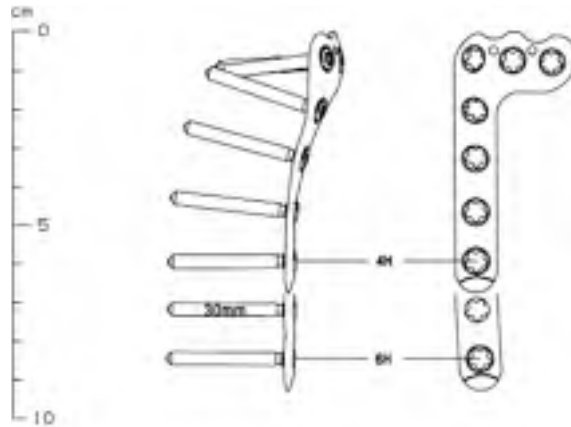

PERI-LOC VLP 3.5mm Lateral Proximal Tibia Locking Plate  
Preoperative Template  
Cat. No. 7118-1182

### Plate Positioning

The Lateral Proximal Tibia Positioning Guide\* (7117-1216, 7117-1217) allows visualization of plate position and provides a template for independent lag screw placement in the proximal tibia prior to plate application. 1.6mm x 150mm K-Wires can be inserted through the two proximal holes in the guide to aid with provisional fixation and fracture reduction. Remove the positioning guide following K-Wire insertion. If desired, the selected plate may then be applied to bone directly over the wires.



The plate sits along the lateral aspect of the proximal tibia. A 5° posterior tilt aligns the proximal row of screws with the contour of the lateral tibial condyle. Plate coverage extending down the shaft is maximized by a 3° sagittal curve in the plate's proximal segment. A proximal row of scallops facilitates external lag screw placement without compromising plate position.



Provisionally fix the plate to bone using K-Wires, Ball Spike Reduction Clamps and/or Provisional Fixation Pins and proceed with screw insertion as desired.

\*The positioning guides are left/right specific

## 3.5mm Posteromedial Proximal Tibia

### Patient Positioning

Place the patient in the supine position on a radiolucent table. Confirm unimpeded AP and lateral visualization of the proximal tibia under fluoroscopy.

### Plate Selection

Following fracture reduction, select the 3.5mm Posteromedial Proximal Tibia Locking Plate that best accommodates patient anatomy and fracture pattern.

**Note** The PERI-LOC<sup>®</sup> VLP 3.5mm Posteromedial Proximal Tibia Locking Plate Preoperative Template (7118-1196) is available to assist with pre-operative radiographic planning.

### Plate Positioning

The plate sits along the posteromedial aspect of the proximal tibia. Scallops at the top of the plate facilitate lag screw placement for joint surface reconstruction without compromising plate position.

Provisionally fix the plate to bone using K-Wires, Ball Spike Reduction Clamps and/or Provisional Fixation Pins and proceed with screw insertion as desired.

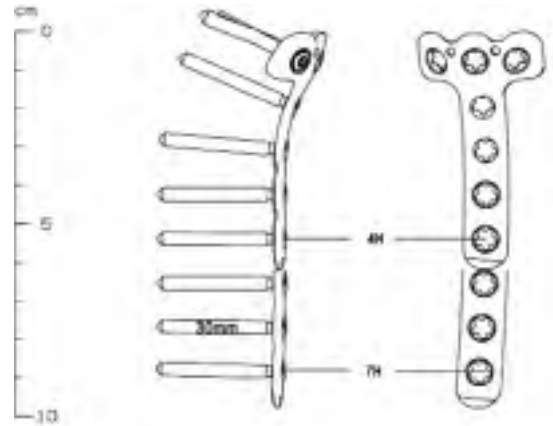

PERI-LOC VLP 3.5mm Posteromedial Proximal Tibia Locking Plate Preoperative Template  
Cat. No. 7118-1196



## 3.5mm Medial Distal Tibia

### Patient Positioning

Place the patient in the supine position on a radiolucent table. Confirm unimpeded AP and lateral visualization of the distal tibia under fluoroscopy.

### Plate Selection

Following fracture reduction, select the 3.5mm Medial Distal Tibia Locking Plate that best accommodates patient anatomy and fracture pattern.

**Note** The PERI-LOC<sup>®</sup> VLP 3.5mm Medial Distal Tibia Locking Plate Preoperative Template (7118-1181) is available to assist with pre-operative radiographic planning.

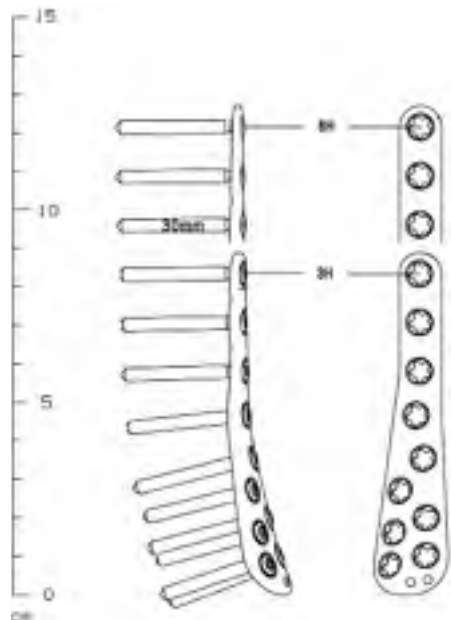

PERI-LOC VLP 3.5mm Medial Distal Tibia Locking Plate  
Preoperative Template  
Cat. No. 7118-1181

### Plate Positioning

The plate sits along the medial aspect of the distal tibia with the distal most screw holes positioned just superior to the plafond.

Provisionally fix the plate to bone using K-Wires, Ball Spike Reduction Clamps, Reduction Forceps and/or Provisional Fixation Pins and proceed with screw insertion as desired.



## 3.5mm Anterior Distal Tibia

### Patient Positioning

Place the patient in the supine position on a radiolucent table. Confirm unimpeded AP and lateral visualization of the distal tibia under fluoroscopy.

### Plate Selection

Following fracture reduction, select the 3.5mm Anterior Distal Tibia Locking Plate that best accommodates patient anatomy and fracture pattern.

**Note** The PERI-LOC<sup>®</sup> VLP 3.5mm Anterior Distal Tibia Locking Plate Preoperative Template (7118-1197) is available to assist with pre-operative radiographic planning.

### Plate Positioning

The Anterior Distal Tibia Positioning Guide (7117-1218) allows visualization of plate position and provides a template for independent lag screw placement in the distal tibia prior to plate application. 1.6mm x 150mm K-Wires can be inserted through the two distal holes in the guide to aid with provisional fixation and fracture reduction. Remove the positioning guide following K-Wire insertion. If desired, the selected plate may then be applied to bone directly over the wires.

The plate sits along the anterior aspect of the distal tibia with its distal tip resting just superior to the tibial plafond. Distal scallops facilitate lag screw placement without compromising plate position.

Provisionally fix the plate to bone using K-Wires, Ball Spike Reduction Clamps, Reduction Forceps and/or Provisional Fixation Pins and proceed with screw insertion as desired.

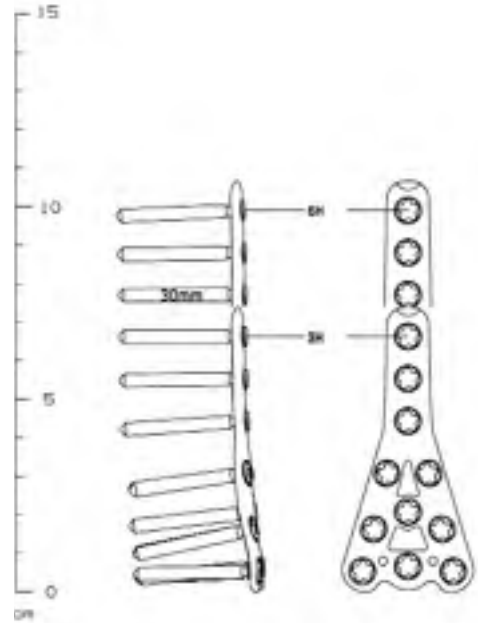

PERI-LOC VLP 3.5mm Anterior Distal Tibia Locking Plate Preoperative Template  
Cat. No. 7118-1197



## 3.5mm Posterior Distal Tibia

### Patient Positioning

Place the patient in the prone position on a radiolucent table. Confirm unimpeded AP and lateral visualization of the distal tibia under fluoroscopy.

### Plate Selection

Following fracture reduction, select the 3.5mm Posterior Distal Tibia Locking Plate that best accommodates patient anatomy and fracture pattern.

**Note** The PERI-LOC<sup>®</sup> VLP 3.5mm Posterior Distal Tibia Locking Plate Preoperative Template (7118-1198) is available to assist with pre-operative radiographic planning.

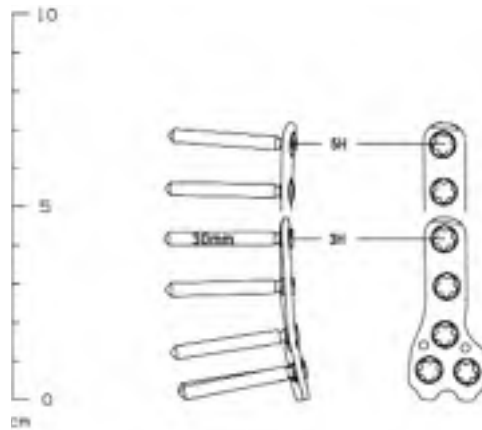

PERI-LOC VLP 3.5mm Posterior Distal Tibia Locking Plate  
Preoperative Template  
Cat. No. 7118-1198

### Plate Positioning

The plate sits along the posterior aspect of the distal tibia with its distal tip resting just superior to the tibial plafond. Distal scallops facilitate lag screw placement without compromising plate position.

Provisionally fix the plate to bone using K-Wires, Ball Spike Reduction Clamps, Reduction Forceps and/or Provisional Fixation Pins and proceed with screw insertion as desired.



## Screw Insertion

Determine which screws are most appropriate for fracture fixation. A combination of 2.7mm Cortex, 3.5mm Cortex, 3.5mm Locking and 5.0mm Osteopenia Screws may be used.

### 3.5mm Cortex Screw

Insert the Universal Drill Guide Handle (7117-1222) with 2.7mm Drill Guide (7117-1227) into the desired screw hole and drill accordingly with the 2.7mm drill bit. Depending upon plate selection and location, either the Short 2.7mm Drill Bit (7117-3502) or Long 2.7mm Drill Bit (7117-3503) will be used.

**Note** The 2.7mm x 3.5mm Drill Guide (7117-1225) is available for independent lag screw placement. The 3.5mm Drill Guide (7117-1226) may be used with the Universal Drill Guide Handle for lag screw placement through the plate.

Measure for screw length by reading the exposed calibrations off the drill or by using the depth gauge. Depending upon the drill bit used, either the Standard Depth Gauge (7117-1231) or the Long Depth Gauge (7117-1232) will be required.

**Note** An additional 50mm must be added to the length of the screw when using the 2.7mm x 3.5mm Drill Guide with the Long 2.7mm Drill Bit as the drill bit is not calibrated to the drill guide. For screws shorter than 50mm in length, use the Standard Depth Gauge.

Insert the appropriate length 3.5mm Self-Tapping Cortex Screw using the 2.5mm Hex Screwdriver (7117-0029).



### 3.5mm Locking Screw and 5.0mm Osteopenia Screw

Insert the Universal Drill Guide Handle with 2.7mm Variable Angle Drill Guide (7117-1219) into the desired screw hole. The drill guide is correctly aligned when its star-shaped tip engages with the five tabs in the hole. Adjust screw trajectory by rotating the tip of the variable angle drill guide 360° within the plate hole and up to 15° in any direction. Drill accordingly with either the Short or Long 2.7mm Drill Bit depending upon plate type and location.

**Note** The 2.7mm x 3.5mm Drill Guide is available for placement of a 5.0mm Osteopenia screw outside the plate. If inserting a 5.0mm Osteopenia screw through the plate as a lag screw, the 2.7mm Variable Angle Drill Guide should be used.

Measure for screw length by reading the exposed calibrations off the drill or by using the depth gauge. Depending upon the drill used, either the Standard or Long Depth Gauge will be required.

**Note** An additional 50mm must be added to the length of the screw when using the 2.7mm x 3.5mm Drill Guide with the Long 2.7mm Drill Bit as the drill bit is not calibrated to the drill guide. For screws shorter than 50mm in length, use the Standard Depth Gauge.

Insert the appropriate length 3.5mm Self-Tapping Locking Screw using the 1.7Nm Torque Limiting Screwdriver\* (7117-1238) and 2.5mm Hexdriver Shaft (7117-0033, 7117-0169). Usage of the torque limiting screwdriver will prevent over-insertion of the locking screw through the star-shaped plate hole. For insertion of a 5.0mm Osteopenia screw, the 2.5mm Hex Screwdriver is used.



\*The 1.7Nm Torque Limiting Screwdriver should be calibrated every six months to ensure optimal instrument performance

### 2.7mm Cortex Screw

Position the 2.0mm x 2.7mm Drill Guide (7117-1224) on bone in the desired location and drill accordingly with the 2.0mm drill bit. The location of the 2.7mm Cortex Screw on bone determines whether the Long 2.0mm Drill Bit (7117-3501) or Short 2.0mm Drill Bit (7117-3588) will be used.



Measure for screw length by reading the exposed calibrations off the drill or by using either the Standard or Long Depth Gauge.

**Note** An additional 50mm must be added to the length of the screw when using the 2.0mm x 2.7mm Drill Guide with the Long 2.0mm Drill Bit as the drill bit is not calibrated to the drill guide. For screws shorter than 50mm in length, use the Standard Depth Gauge.



Insert the appropriate length 2.7mm Self-Tapping Cortex Screw using the 2.5mm Hex Screwdriver.

**Note** The 2.7mm Cortex Screw cannot be inserted into any of the PERI-LOC<sup>®</sup> VLP Locking Plates due to its smaller head size. It is used for low profile fracture reduction and fixation external to the plate.



### Stripped Hex Screw Removal

Attach the Screw Extractor\* (7117-1237) to the Tear Drop Screwdriver Handle (7117-3543) and insert into the recess of the screw. Turn the extractor assembly counterclockwise to remove the screw. The Screw Extractor is compatible with all PERI-LOC VLP screws.

\*Located in the PERI-LOC VLP Instrument Tray

## Closure

Obtain final AP and lateral radiographic images to confirm implant position and fracture reduction. Wound closure follows standard technique.



# Catalog Information



## PERI-LOC® VLP Instrument Set

Set No. 7181-2301

### Instrument Case

Cat. No.	Description
7117-0404	PERI-LOC VLP Instrument Tray
7117-0410	PERI-LOC VLP Instrument Tray Lid
7117-0396	PERI-LOC VLP Drill Caddy

### Instruments

Cat. No.	Description	Qty	Cat. No.	Description	Qty
7117-0043	Sharp Hook	1	7117-3543	Tear Drop Screwdriver Handle	1
7117-3369	Hohmann Retractor Bent	2	7117-1238	1.7Nm Torque Limiting Screwdriver	1
7117-0057	Hohmann Retractor Bent 8mm	2	7117-0029	2.5mm Hex Screwdriver, Small	1
7117-0095	Hohmann Retractor Bent 15mm	2	7117-0031	Holding Sleeve	1
7117-0097	Periosteal Elevator, 6mm Curved	1	7117-1224	2.0mm X 2.7mm Drill Guide	1
7117-0063	Wire Bending Pliers, 140mm	1	7117-1225	2.7mm X 3.5mm Drill Guide	1
7117-3377	Reduction Forceps Broad	2	7117-1226	3.5mm Drill Guide	1
7117-3378	Reduction Forceps Serrated Jaws	2	7117-1227	2.7mm Drill Guide	1
7117-1219	2.7mm Variable Angle Drill Guide	1	7117-1237	Screw Extractor	1
7117-1222	Universal Drill Guide Handle with Quick Connect	1	7117-1233	Plate Bending Irons	2
7117-1231	Standard Depth Gauge (6mm – 55mm)	1	7117-3344	3.5mm Countersink	1
7117-1232	Long Depth Gauge (6mm – 110mm)	1	7117-0033	2.5mm Hexdriver Shaft – 100mm	2
7117-3528	AO – Trinkle	1	7117-0169	2.5mm Hexdriver Shaft – 165mm	1

### VLP Disposable Set

Set No. 7181-2302

Cat. No.	Description	Qty	Cat. No.	Description	Qty
7116-1012	1.25mm X 150mm K-wire	6	7117-3501	Long 2.0mm Drill Bit, 190mm	1
7116-1016	1.6mm X 150mm K-wire	6	7117-3502	Short 2.7mm Drill Bit, 155mm	2
7116-1020	2.0mm X 150mm K-wire	6	7117-3503	Long 2.7mm Drill Bit, 228mm	2
7117-1228	2.7mm X 14mm PF Pin	2	7117-3504	3.5mm Drill Bit, 155mm	2
7117-1229	2.7mm X 25mm PF Pin	2	7117-3366	2.7mm Tap	1
7117-1230	2.7mm X 40mm PF Pin	2	7117-3318	3.5mm Tap	1
7117-3588	Short 2.0mm Drill Bit, 157mm	1			

# Catalog Information



## PERI-LOC<sup>®</sup> Periarticular Forceps Set

Set No. 7181-2300

### Instrument Case

Cat. No.	Description
7117-0411	PERI-LOC Periarticular Forceps Tray
7117-0412	PERI-LOC Periarticular Forceps Tray Lid

### Instruments

Cat. No.	Description	Qty	Cat. No.	Description	Qty
7117-1210	Ball Spike Pusher	1	7117-0044	Reduction Forceps, w/ Ratchet 205mm	1
7117-1212	Ball Spike Reduction Clamp, Medium	1	7117-3370	Reduction Forceps, w/ Bowed Ratchet 205mm	1
7117-1213	Ball Spike Reduction Clamp, Large	1	7117-3377	Reduction Forceps Broad	2
7117-1220	15mm Spiked Washer	2	7117-3378	Reduction Forceps Serrated Jaws	2
7117-1221	25mm Spiked Washer	2			
7117-1211	Fibula Clamp	1			



## PERI-LOC<sup>®</sup> VLP Implant Set

Set No. 7181-2200

### Instrument Case

Cat. No.	Description	Cat. No.	Description
7117-0394	PERI-LOC VLP Implant Tray	7117-0402	PERI-LOC VLP Screw Caddy
7117-0406	PERI-LOC VLP Implant Tray Lid	7117-0408	PERI-LOC VLP Screw Caddy Lid
7117-0413	PERI-LOC VLP Proximal Tibia Locking Plate Tray	7117-0417	PERI-LOC VLP Auxiliary Screw Caddy
7117-0414	PERI-LOC VLP Proximal Tibia Locking Plate Tray Lid	7117-0418	PERI-LOC VLP Auxiliary Screw Caddy Lid
7117-0415	PERI-LOC VLP Distal Tibia/Fibula Locking Plate Tray		
7117-0416	PERI-LOC VLP Distal Tibia/Fibula Locking Plate Tray Lid		

### Instruments

Cat. No.	Description	Qty
7117-1216	Lateral Proximal Tibia Positioning Guide, Right	1
7117-1217	Lateral Proximal Tibia Positioning Guide, Left	1
7117-1218	Anterior Distal Tibia Positioning Guide	1
7117-0002	Screw Forcep	1

# Catalog Information

## Implants

### 3.5mm Posteromedial Proximal Tibia Locking Plates

<u>Cat. No.</u>	<u>Description</u>	<u>Length</u>	<u>Cat. No.</u>	<u>Description</u>	<u>Length</u>
7282-0104	4H, Left	64mm	7282-0204	4H, Right	64mm
7282-0107	7H, Left	98mm	7282-0207	7H, Right	98mm

### 3.5mm Lateral Proximal Tibia Locking Plates

<u>Cat. No.</u>	<u>Description</u>	<u>Length</u>	<u>Cat. No.</u>	<u>Description</u>	<u>Length</u>
7282-0304	4H, Left	68mm	7282-0404	4H, Right	68mm
7282-0306	6H, Left	93mm	7282-0406	6H, Right	93mm

### 3.5mm Posterior Distal Tibia Locking Plates

<u>Cat. No.</u>	<u>Description</u>	<u>Length</u>	<u>Cat. No.</u>	<u>Description</u>	<u>Length</u>
7282-0203	3H, Left	47mm	7282-0303	3H, Right	47mm
7282-0205	5H, Left	72mm	7282-0305	5H, Right	72mm

### 3.5mm Anterior Distal Tibia Locking Plates

<u>Cat. No.</u>	<u>Description</u>	<u>Length</u>
7282-0503	3H	74mm
7282-0506	6H	107mm

### 3.5mm Medial Distal Tibia Locking Plates

<u>Cat. No.</u>	<u>Description</u>	<u>Length</u>	<u>Cat. No.</u>	<u>Description</u>	<u>Length</u>
7282-0603	3H, Left	89mm	7282-0703	3H, Right	89mm
7282-0606	6H, Left	127mm	7282-0706	6H, Right	127mm

### 3.5mm Posterolateral Distal Fibula Locking Plates

<u>Cat. No.</u>	<u>Description</u>	<u>Length</u>	<u>Cat. No.</u>	<u>Description</u>	<u>Length</u>
7282-0805	5H, Left	62mm	7282-0905	5H, Right	62mm
7282-0806	6H, Left	74mm	7282-0906	6H, Right	74mm
7282-0807	7H, Left	86mm	7282-0907	7H, Right	86mm

### 3.5mm Lateral Distal Fibula Locking Plates

Cat. No.	Description	Length	Cat. No.	Description	Length
7282-1003	3H, Left	59mm	7282-2003	3H, Right	59mm
7282-1004	4H, Left	71mm	7282-2004	4H, Right	71mm
7282-1005	5H, Left	83mm	7282-2005	5H, Right	83mm
7282-1007	7H, Left	107mm	7282-2007	7H, Right	107mm
7282-1009	9H, Left	131mm	7282-2009	9H, Right	131mm
7282-1011	11H, Left	155mm	7282-2011	11H, Right	155mm

### 3.5mm One-Third Locking Tubular Plates

Cat. No.	Description	Length	Cat. No.	Description	Length
7282-3005	5H	62mm	7280-3008*	8H	98mm
7282-3006	6H	74mm	7280-3010*	10H	122mm
7282-3007	7H	86mm	7280-3012*	12H	146mm

### 2.7mm Self-Tapping Cortex Screws

Cat. No.	Length	Cat. No.	Length
7182-3010	10mm	7182-3036	36mm
7182-3012	12mm	7182-3038	38mm
7182-3014	14mm	7182-3040	40mm
7182-3016	16mm	7182-3042	42mm
7182-3018	18mm	7182-3044	44mm
7182-3020	20mm	7182-3046	46mm
7182-3022	22mm	7182-3048	48mm
7182-3024	24mm	7182-3050	50mm
7182-3026	26mm	7182-3055	55mm
7182-3028	28mm	7182-3060	60mm
7182-3030	30mm	7182-3065	65mm
7182-3032	32mm	7182-3070	70mm
7182-3034	34mm		

### 2.7mm Cortex Screws (Non Self-Tapping)

Cat. No.	Length	Cat. No.	Length
7182-3310**	10mm	7182-3318**	18mm
7182-3312**	12mm	7182-3320**	20mm
7182-3314**	14mm	7182-3322**	22mm
7182-3316**	16mm		

\*Available sterile only

\*\*Optional screws

# Catalog Information

## 3.5mm Self-Tapping Locking Screws

Cat. No.	Length	Cat. No.	Length	Cat. No.	Length
7182-1206	6mm	7182-1230	30mm	7182-1260	60mm
7182-1208	8mm	7182-1232	32mm	7182-1265	65mm
7182-1210	10mm	7182-1234	34mm	7182-1270	70mm
7182-1212	12mm	7182-1236	36mm	7182-1275	75mm
7182-1214	14mm	7182-1238	38mm	7182-1280	80mm
7182-1216	16mm	7182-1240	40mm	7180-1285*	85mm
7182-1218	18mm	7182-1242	42mm	7180-1290*	90mm
7182-1220	20mm	7182-1244	44mm	7180-1295*	95mm
7182-1222	22mm	7182-1246	46mm	7180-1296*	100mm
7182-1224	24mm	7182-1248	48mm	7180-1297*	105mm
7182-1226	26mm	7182-1250	50mm	7180-1298*	110mm
7182-1228	28mm	7182-1255	55mm		

## 3.5mm Self-Tapping Cortex Screws

Cat. No.	Length	Cat. No.	Length	Cat. No.	Length
7182-1306	6mm	7182-1330	30mm	7182-1360	60mm
7182-1308	8mm	7182-1332	32mm	7182-1365	65mm
7182-1310	10mm	7182-1334	34mm	7182-1370	70mm
7182-1312	12mm	7182-1336	36mm	7182-1375	75mm
7182-1314	14mm	7182-1338	38mm	7182-1380	80mm
7182-1316	16mm	7182-1340	40mm	7180-1385*	85mm
7182-1318	18mm	7182-1342	42mm	7180-1390*	90mm
7182-1320	20mm	7182-1344	44mm	7180-1395*	95mm
7182-1322	22mm	7182-1346	46mm	7180-1396*	100mm
7182-1324	24mm	7182-1348	48mm	7180-1397*	105mm
7182-1326	26mm	7182-1350	50mm	7180-1398*	110mm
7182-1328	28mm	7182-1355	55mm		

## 3.5mm Cortex Screws (Non Self-Tapping)

Cat. No.	Length	Cat. No.	Length
7182-3510**	10mm	7182-3518**	18mm
7182-3512**	12mm	7182-3520**	20mm
7182-3514**	14mm	7182-3522**	22mm
7182-3516**	16mm		

\*Available sterile only  
\*\*Optional screws

### 5.0mm Osteopenia Screws, Fully Threaded

Cat. No.	Length	Cat. No.	Length	Cat. No.	Length
7182-2010	10mm	7182-2034	34mm	7182-2070	70mm
7182-2012	12mm	7182-2036	36mm	7182-2075	75mm
7182-2014	14mm	7182-2038	38mm	7182-2080	80mm
7182-2016	16mm	7182-2040	40mm	7180-2085*	85mm
7182-2018	18mm	7182-2042	42mm	7180-2090*	90mm
7182-2020	20mm	7182-2044	44mm	7180-2095*	95mm
7182-2022	22mm	7182-2046	46mm	7180-2096*	100mm
7182-2024	24mm	7182-2048	48mm	7180-2097*	105mm
7182-2026	26mm	7182-2050	50mm	7180-2098*	110mm
7182-2028	28mm	7182-2055	55mm		
7182-2030	30mm	7182-2060	60mm		
7182-2032	32mm	7182-2065	65mm		

### 5.0mm Osteopenia Screws, Partially Threaded

Cat. No.	Length	Cat. No.	Length	Cat. No.	Length
7182-1126	26mm	7182-1144	44mm	7182-1180	80mm
7182-1128	28mm	7182-1146	46mm	7180-1185*	85mm
7182-1130	30mm	7182-1148	48mm	7180-1190*	90mm
7182-1132	32mm	7182-1150	50mm	7180-1195*	95mm
7182-1134	34mm	7182-1155	55mm	7180-1196*	100mm
7182-1136	36mm	7182-1160	60mm	7180-1197*	105mm
7182-1138	38mm	7182-1165	65mm	7180-1198*	110mm
7182-1140	40mm	7182-1170	70mm		
7182-1142	42mm	7182-1175	75mm		

### Washer, 7.0mm Outer Diameter

Cat. No. 7114-3107

\*Available sterile only







We are proud to be a Diamond Level  
Supporter of the Research and Education  
of the Orthopaedic Trauma Association

**Orthopaedic Trauma &  
Clinical Therapies**

Smith & Nephew, Inc.  
1450 Brooks Road  
Memphis, TN 38116  
USA

[www.smith-nephew.com](http://www.smith-nephew.com)

Telephone: 1-901-396-2121  
Information: 1-800-821-5700  
Orders/Inquiries: 1-800-238-7538